

SEP 100

SEP Series – Stamping presses for every application

SCHAAL
by Weil Technology



Visit our
website



02 2022

Technical Data

Press force	1000 kN (available from 100 strokes/min)
Stroke rate	stepless up to 320 strokes/min
Distance between table and ram (with clamping bars), largest stroke at the bottom, adjustment at the top	320 mm
Ram adjustment	100 mm
Ram stroke – adjustable	10 – 100 mm
Ram Plate (L x W x H)	800 × 600 × 50 mm
Fitting groove in the ram	30 H7 mm
Table surface (L x W)	1050 × 860 mm
Mould dimensions (L x W)	1010 × 760 mm
Clamping bars thickness	100 mm
Through-hole clamping bars (L x W)	straight x 100 – 220 mm (adjustable)
Through-hole in the table (L x W)	840/720 × 260 mm
Belt infeed above clamping surface	feed-dependent
Drive power	22 kW
Weight (without feed)	13000 kg
Dimensions (L x W x H)	2400 × 1550 × 3000 mm

Technical changes reserved.

Structure

- Press body in stable double-column monoblock design made of vibration-damping gray cast iron
- Eccentric shaft on roller bearings with adjustment stroke and rotating mass balance
- Air-cooled piston rod, mounted on the eccentric shaft with multi-row, heavy-duty caged roller bearings
- Press ram made of high-strength titanium alloyed cast Al, 6-fold backlash-free rolling bearing supported by linear roller bearings on hardened and ground guideways
- Press drive via frequency-controlled three-phase motor, flywheel and pneumatic clutch-brake combination and planetary gear
- Press sequence control in PLC technology
- Press control with cam controller, mould and press force monitoring
- Special/additional equipment possible at any time by technical arrangement
- The SEP 100 stamping press can be individually equipped with gripper or roller feeds pushing or pulling

SEP 100

SEP Series – Stamping presses for every application

Dimensions

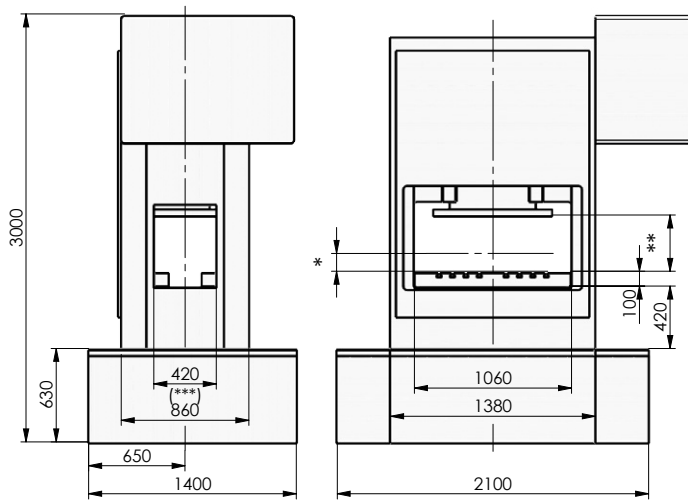

- * Belt feed height above clamping surface on request (feed-dependent)
- ** Mould installation height (see table)
- *** The lateral passage on the press body is reduced to **260 mm** when a gripper feed is used (special widths on request)

Ram stroke in mm	Mould installation height min. – max	Permissible stroke rate depending on ram stroke
10	265 – 365	320
13	263 – 363	315
20	260 – 360	310
27	256 – 356	300
35	252 – 352	270
43	248 – 348	250
50	245 – 345	230
58	241 – 341	215
64	238 – 338	200
71	234 – 334	190
77	231 – 331	185
82	229 – 329	180
86	227 – 327	170
90	225 – 325	155
94	223 – 323	140
96	222 – 322	130
99	221 – 321	115
100	220 – 320	110
mechanically adjustable	Installation height in mm for bottom ram stroke (BDC) with ram plate (without = plus 50 mm)	with maximum mould upper part weight of 380 kg

Ram Surface

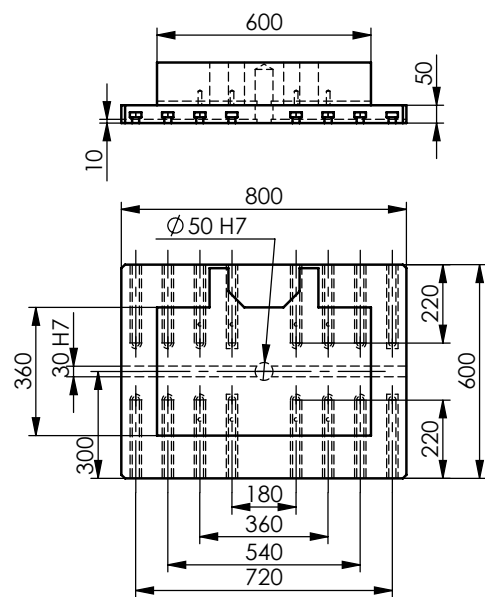

Mould mounting surface

